



# Automotive Verification Test Systems AVTS

Installation test systems for the automobile industry

Basic systems for:

- Radio: AM, FM
- Television: PAL, NTSC, SECAM
- Mobile radio: GSM, TDMA, CDMA
- Navigation: GPS
- Customer applications



**ROHDE & SCHWARZ**



## Concept

Thanks to the close cooperation of Rohde&Schwarz with specialists from the automobile industry and their early integration into new projects, optimal solutions for given test requirements can be made available in time.

We thus create solutions today for the requirements of tomorrow. This is exemplified by the installation of digital TV (DVB-T) in future vehicles, or the integration of new standards. The Rohde&Schwarz system is modular and forward-looking, allowing the easy integration of new solutions into existing systems.

## Method

To be able to test any kind of equipment installed in the motor vehicle, all the test signals are applied to the vehicle antenna at the same time and with constant power via an antenna connected to the system. The antenna

## General

Consumer and communications electronics for motor vehicles is an ever growing market. This calls for new and complex test strategies for use in automobile production. Moreover, the following aspects are vital for market success:

- motor vehicle quality,
- customer satisfaction and
- name of automobile manufacturer.

Rohde&Schwarz closely cooperates with well-known automobile manufacturers and vehicle component suppliers. This has built up a wealth of experience in the development and implementation of test strategies, resulting in test systems that are optimally matched to manufacturers' requirements.

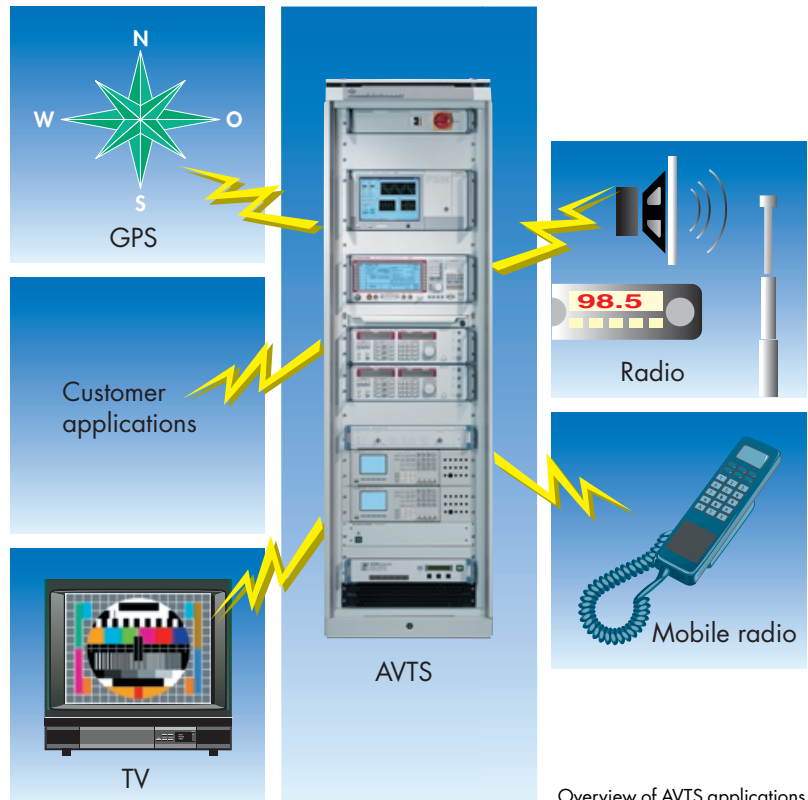

Overview of AVTS applications

## Antenna



System

transmitting the test signals is mounted in the hall above the production line (see picture above).

A special antenna design is used which makes it possible to illuminate production lines up to a length of 150 m.

### Radio test systems

The car radio installation test systems AVTS-AM and AVTS-FM allow the simple and cost-effective testing of vehicle components such as antennas, antenna amplifiers, car radios and associated cabling. Simple loudspeaker tests, too, can be performed.

AM tests are mainly carried out on vehicles intended for export, for example to the U.S. or Africa, where AM radio is of vital importance for the coverage of large geographical areas.

The AVTS-FM car radio installation test system employs a special slot antenna. Compared with the AVTS-AM system, which uses a long-wire antenna, AVTS-FM offers the important advantage that transmission characteristics are approximately constant over long runs of the production line. This allows tighter test criteria to be defined. Another advantage offered by

AVTS-FM is enhanced immunity to external interference, such as from fluorescent lamps.

The two systems can of course be combined into one, or conversion or upgrade can be carried out at any time.

### Loudspeaker test system

Loudspeakers fitted in vehicles can be tested by means of the AVTS-LS installation test system.

This system is based on the AVTS-FM test system. Instead of a single tone, a multitone signal is generated to match the loudspeaker combination built into the vehicle (eg treble, medium-frequency or bass). The individual tones are sent to the car radio under computer control. The loudspeaker combination to be tested is selected by means of the fader and balance control of the radio.

AVTS used in automobile production line

The tone sequence activates the corresponding loudspeaker (treble, medium-frequency or bass). The tone from the loudspeaker is evaluated by a test person or, alternatively, analyzed by means of a test radio microphone in the vehicle and an audio analyzer integrated in the test system (at a higher system configuration level).

For car radios capable of being diagnosed, fader and balance can be controlled via the vehicle bus. This allows fully automatic testing and analysis.

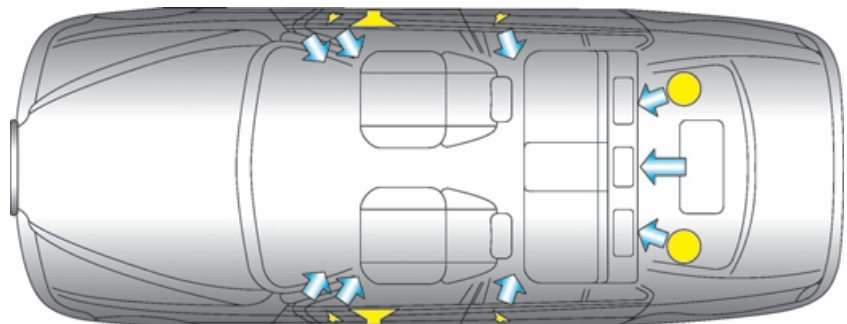

Position of loudspeakers

## TV test systems

To verify proper installation and functioning of TV components installed in the vehicle, test patterns are selected from the TV generators of the AVTS and emitted via the slot antenna. The received picture quality in the vehicle is evaluated by a test person. Compliance with test specifications of international standards is ensured through the use of appropriate TV signal generators.

To emit signals of several TV standards simultaneously, for example on a production line for export vehicles, one generator per TV standard has to be used.

## Mobile-radio test systems

With mobile-radio test system AVTS-GSM, AVTS-CDMA and AVTS-TDMA, Rohde&Schwarz offers a complete system for testing mobile-radio components installed in vehicles (eg antennas, antenna amplifiers, phones and cabling).

The software supplied with the system serves to

- simplify car phone measurements in vehicle production,
- ensure reliable phone links and
- test car phones of different power classes.

All this is necessary to assess the quality of installation in the vehicle.

The most comprehensive test is effected by the AVTS-GSM software in the echo test mode, in which all audio components of the car telephone are tested, including the hands-free facility.

### AVTS-GSM system software

The AVTS-GSM software informs the user on status and results in large display windows (see pictures below).

All test results are archived for documentation and further processing. The system has an integrated network interface so that information can be routed to data networks.

## Navigation test system

The AVTS-GPS test system supplies the GPS signal to the vehicles in the production hall.

Normally, a direct line of sight to the GPS satellite is required for reception of the GPS signal. However, the signal is shadowed by the roof of the production hall, so it has to be taken inside the hall with a repeater and then emitted via antennas. Using this method, the vehicle navigation system under test can "learn" the GPS signal in the production hall and synchronize to the signal.

Proper installation is verified by means of the vehicle navigation system itself.

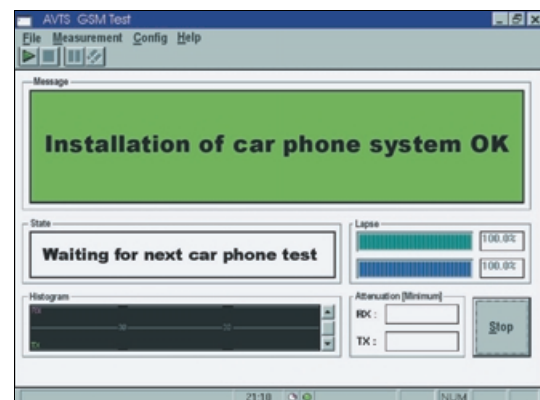
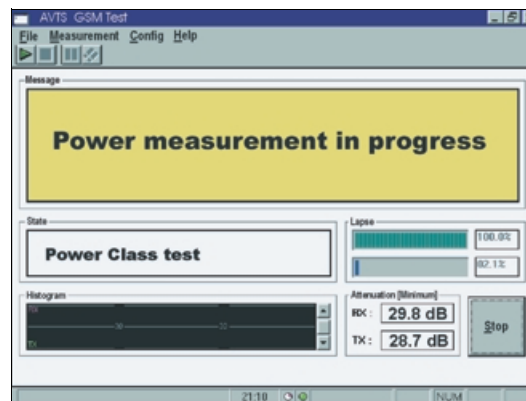

## Configuration

The photo below shows a typical combination of several applications (GSM, AM, FM, TV-PAL, TV-NTSC) in a system rack. This solution takes up considerably less space on the production floor than isolated systems.



## Extendable for future applications

A great advantage of the Rohde & Schwarz system concept is its modularity. Any existing test system (eg AVTS-AM) can be extended to include further functionalities (eg FM, GSM) without elaborate modification.

## Components diagnosis

The vehicle bus permits the diagnosis of today's advanced communication devices. The levels received at the car radio, GSM phone, TV set, etc are read out by the car manufacturer's diagnostics equipment and undergo automatic pass/fail evaluation.

It is also possible to control the devices via the vehicle's diagnostic bus. In conjunction with the AVTS test system, further fully automatic test sequences can be generated.

## Quality standard

The AVTS installation test system is manufactured and tested at the Rohde & Schwarz Cologne Plant in conformance with the ISO9001 quality standard.





**ROHDE & SCHWARZ**

ROHDE & SCHWARZ GmbH & Co. KG · Koeln · Graf-Zeppelin-Strasse 18 · 51147 Koeln, Germany  
P. O. B. 98 02 60 · 51130 Koeln, Germany · Telephone +492203 49 405, Fax +492203 49 364